

PACKAGED TERMINAL AIR CONDITIONER/HEAT PUMP
Owner's Manual
Installation & Operation



GENUINE COMFORT
DELIVERING COMFORT CONSISTENTLY

Ultra Series 42" Inverter PTHP

MODELS

9,000 BTU	12,000 BTU	15,000 BTU
GC42U-H09KA2-1	GC42U-H12KC3-1	GC42U-H15KC3-1
GC42U-H09KC3-1	GC42U-H12KD5-1	GC42U-H15KD5-1
GC42U-H09KA2-1-M	GC42U-H12KC3-1-M	GC42U-H15KC3-1-M
GC42U-H09KC3-1-M	GC42U-H12KD5-1-M	GC42U-H15KD5-1-M

MODEL CODING

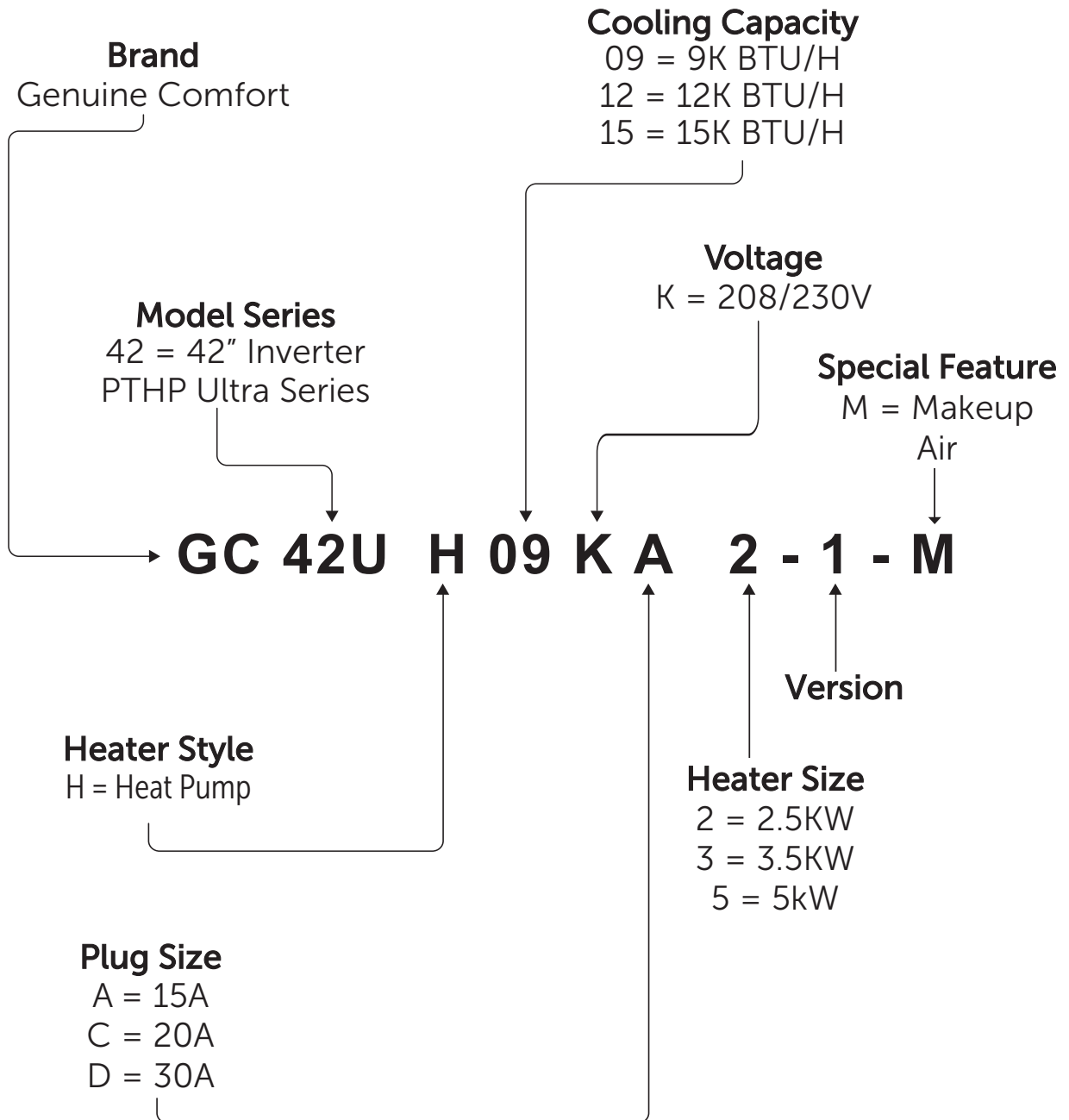

CONTENTS

Safety Precautions	01
Before You Get Started	13
Installation Overview	14
Product Installation	15
DIP Switch Configurations	18
DIP Switch Configurations by Panel Control (optional)	20
Wall Thermostat Terminal (optional)	22
Operation Instructions	25
App Setup and Operation (optional)	28
Care and Maintenance	32
Troubleshooting	33

Safety Precautions

It's important that you read Safety Precautions Before Operation and Installation. Incorrect installation due to ignoring instructions can cause serious damage or injury. The seriousness of potential damage or injuries is classified as either a WARNING or CAUTION.

Explanation of Symbols



WARNING

The signal word indicates a hazard with a medium level of risk which, if not avoided, may result in death or serious injury.



CAUTION

The signal word indicates a hazard with a low degree of risk which, if not avoided, may result in minor or moderate injury.



NOTE

This signal word indicates important information (e.g., damage to property), but not danger.

Read these operating instructions carefully and attentively before using/commissioning the unit and keep them in the immediate vicinity of the installation site or unit for later use!

CAUTION

- This appliance can be used by children aged from 8 years and above and persons with reduced physical, sensory or mental capabilities or lack of experience and knowledge if they have been given supervision or instruction concerning use of the appliance in a safe way and understand the hazards involved. Children shall not play with the appliance. Cleaning and user maintenance shall not be made by children without supervision. (Be applicable for the European Countries.)
- This appliance is not intended for use by persons (including children) with reduced physical, sensory or mental capabilities or lack of experience and knowledge, unless they have been given supervision or instruction concerning use of the appliance by a person responsible for their safety. (Be applicable for other countries except the European Countries.)
- Children should be supervised to ensure that they do not play with the appliance.
- If the supply cord is damaged, it must be replaced by the manufacturer, its service agent or similarly qualified persons in order to avoid a hazard.
- The appliance shall be installed in accordance with national wiring regulations.
- Do not operate your air conditioner in a wet room such as a bathroom or laundry room.
- The appliance with electric heater shall have at least 1 meter space to the combustible materials.

WARNING

- State of California Proposition 65 Warning (US Only). This product contains chemicals known to the State of California to cause cancer, birth defects, or other reproductive harm.
- Plug in the power plug properly. Otherwise, it may cause electric shock or fire due to excess heat generation.
- Do not operate or stop the unit by inserting or pulling out the power plug. It may cause electric shock or fire due to heat generation.
- Do not damage or use an unspecified power cord. It may cause electric shock or fire.
- Always install a circuit breaker and a dedicated power circuit. Incorrect installation may cause fire and an electric shock. Do not operate with wet hands or in a damp environment. It may cause electric shock. Do not direct airflow at room occupants only. This could damage your health.
- Always ensure effective grounding. Incorrect grounding may cause electric shock.
- Do not allow water to run into electric parts. It may cause failure of the machine or electric shock.
- Do not modify the power cord length or share the outlet with other appliances. It may cause electric shock or fire due to heat generation.
- Unplug the unit if strange sounds, smells, or smoke come from it. It may cause fire and electric shock.
- Do not use the socket if it is loose or damaged. It may cause fire and electric shock.
- Do not open the unit during operation. It may cause an electric shock.
- Keep firearms away. It may cause fire. Do not use the power cord close to heating appliances. It may cause fire and electric shock. Do not use the power cord near flammable gas or combustibles, such as gasoline, benzene, thinner, etc. It may cause an explosion or fire.
- Ventilate the room before operating the air conditioner if there is a gas leakage from another appliance. It may cause explosion, fire and, burns. Do not disassemble or modify unit. It may cause failure and electric shock.

CAUTION

- When the air filter is to be removed, do not touch the metal parts of the unit. It may cause an injury.
- Ventilate the room well when used together with a stove, etc. An oxygen shortage may occur.
- Do not use strong detergents such as wax or thinner but, use a soft cloth. Appearance may be deteriorated due to a change of product color or the scratching of its surface. Do not clean the air conditioner with water. Water may enter the unit and degrade the insulation. It may cause an electric shock. Do not use for special purposes. Do not use this air conditioner to preserve precision devices, food, pets, plants, or art objects. It may cause deterioration of quality, etc.
- Stop the operation and close the window in a storm or hurricane. Operation with windows opened may cause wetting of indoor and soaking of household furniture. When the unit is to be cleaned, switch off, and turn off the circuit breaker.
- Do not clean unit when power is on as it may cause fire and electric shock, it may cause an injury.
- Always insert the filters securely. It can cause failure if operated without filters. Please clean the filter once every 3 months.

CAUTION

- Hold the plug by its head when removing it. It may cause electric shock and damage. Turn off the main power switch when not using the unit for a long time. It may cause failure of the product or fire.
- Do not place obstacles around air inlets or inside of air outlets. It may cause failure of the appliance or an accident. Do not place a heavy object on the power cord and ensure that the cord is not compressed. There is a danger of fire or electric shock. Don't drink water drained from the air conditioner. It contains contaminants and could make you sick.
- Use caution when unpacking and installing. Sharp edges could cause injury.
- If water enters the unit, turn the unit off at the power outlet and switch off the circuit breaker. Isolate the supply by taking the power plug out and contacting a qualified service technician.
- Contact the authorized service technician for repair or maintenance of this unit.
- Contact the authorized installer for installation of this unit.

NOTE

This air conditioner is designed to be operated under the following conditions:

Cooling operation	Outdoor temp.	32°F-122°F/0°C-50°C
	Indoor temp.	61°F-90°F/16°C-32°C
Heating operation	Outdoor temp.	23°F-75°F/-5°C-24°C
	Indoor temp.	32°F-81°F/0°C-27°C







Performance may be reduced outside of these operating temperatures.

Operation of Current Device

The power supply cord contains a current device that senses damage to the power cord. To test your power supply cord, do the following:

- Plug in the Air Conditioner.
- The power supply cord will have TWO buttons on the plug head. Press the TEST button, and you will notice a click as the RESET button pops out.
- Press the RESET button again, and you will notice a click as the button engages.
- The power supply cord is now supplying electricity to the unit. (On some products, this is also indicated by a light on the plug head).

NOTE

Receptacles/ Sub-bases						
Power Supply	230/208V 15 Amp	230/208V 20 Amp	230/208V 30 Amp	265V 15 amp	265V 20 amp	265V 30 amp

The shape may be different according to its model.

CAUTION

1. Do not pour water into the air outlet.
2. When restarting heating mode after powering off, wait 30 seconds to 3 minutes for the four-way valve to reset and compressor protection.
3. If the self-cleaning function is activated, the unit will continue operating to complete the self-cleaning cycle before shutting down.
4. When paired with a fresh air system, note that the fresh air intake may affect indoor temperature and energy consumption. In auto mode, the unit will regulate the fresh air system according to preset control logic.
5. For non-internal drainage installations, ensure a 3-degree outward tilt during installation.
6. If a high-heat unit is equipped with a water pump, clean the pump every three months. A slight water-pumping sound may occur when condensate levels are low.
7. Electric heating mode defaults to high or turbo airflow setting.
8. The airflow grille can be rotated 180° for installation, requiring removal of the limiter posts on the grille in such cases.
9. A mild odor may occur during the first 10 minutes of initial use, after prolonged inactivity, or when activating the electric heating. Maintain ventilation during these scenarios.
10. Do not put obstacles around the air inlet or inside of air outlet of the unit, such as a window curtain etc. Do not allow liquid to run into the air inlet or air outlet.
11. Moving and hot parts. Do not operate the unit with the front panel and rear grille removed.
12. The evaporator must be cleaned once every three months by professional people.

⚠ WARNING

Electrical Information

The complete electrical rating of your new PTHP air conditioner is stated on the serial plate. Refer to the rating when checking the electrical requirements.

- Be sure the air conditioner is properly grounded. To minimize shock and fire hazards, proper grounding is important. The power cord is equipped with a three-prong grounding plug for protection against shock hazards.
- Your equipment must be used in a properly grounded wall receptacle. If the wall receptacle you intend to use is not adequately grounded or protected by a time delay fuse or circuit breaker, have a qualified electrician install the proper receptacle. Ensure the receptacle is accessible after the unit installation.
- Do not run the equipment without a side protective cover in place. This could result in mechanical damage within the air conditioner.
- Do not use an extension cord or an adapter plug.

For Your Safety

- Do not store or use gasoline or other flammable vapors and liquids in the vicinity of this or any other appliance.
- Avoid fire hazard or electric shock. Do not use an extension cord or an adapter plug. Do not remove any prongs from the power cord.

Prevent Accidents

To reduce the risk of fire, electrical shock, or injury to persons when using your air conditioner, follow basic precautions, including the following:

- Be sure the electrical service is adequate for the model you have chosen. This information can be found on the serial plate, which is located on the side of the cabinet and behind the grille.
- Be sure the air conditioner has been securely and correctly installed according to the installation instructions in this manual. Save this manual for possible future use in removing or installing this unit. When handling the air conditioner, be careful to avoid cuts from sharp metal fins on the front and rear coils.

🔊 NOTE

- The power supply cord with this air conditioner contains a current detection device designed to reduce the risk of fire. If the power cord is damaged, it cannot be repaired – it must be replaced with a cord from the product manufacturer.
- Do not use this device to turn the unit on or off.
- Always make sure the RESET button is pushed in for correct operation.
- The power supply cord must be replaced if it fails to reset when either the TEST button is pushed or if it cannot be reset. A new one can be obtained from the product manufacturer.
- If the power supply cord is damaged, it cannot be repaired. It **MUST** be replaced by one obtained from the product manufacturer.
- When 265V units are to be installed, the power supply must be permanent wiring. Permanent wiring may be done through the accessory subbase. An exposed cord connection on 265V units is not permitted.

Grounding-type wall receptacle

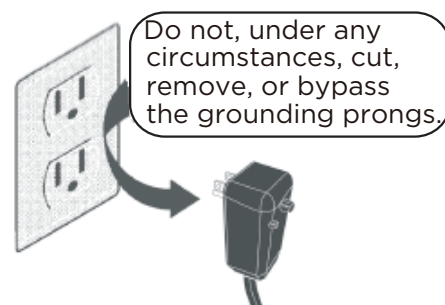

Power supply cord with 3-prong grounding plug and current detection device.

⚠ WARNING

Electrical Requirements

Electrical Shock and Personal Injury Hazard

Electrical ground is required on this appliance.

DO NOT ground to a gas line.

If cold water pipe is interrupted by plastic, non-metallic gaskets, or other insulating materials,

DO NOT use for grounding.

Check with a qualified electrician if you are in doubt as to whether the appliance is properly grounded.

DO NOT modify the power supply cord plug. If it does not fit the outlet, have a proper outlet installed by a qualified electrician.

DO NOT have a fuse in the neutral or grounding circuit. A fuse in the neutral, or grounding circuit, could result in an electrical shock.

DO NOT use an extension cord with this appliance.

Failure to follow these instructions could result in electrical shock, serious injury, or death.

Observe all local governing codes and ordinances. Do not, under any circumstances, remove the power supply cord grounding prong.

NOTE: If codes permit, and a separate grounding wire is used, it is recommended that a qualified electrician determine that the grounding path is adequate and not interrupted by plastic, non-metallic gaskets, or other insulating materials.

Receptacle wiring

Receptacle wiring should be a minimum of 14-gauge. Use copper wire only. It is your responsibility to provide proper and adequate receptacle wiring, installed by a qualified electrician.

Electrical requirements

A time delay fuse or time delay circuit breaker is also required.

A separate circuit, serving only this appliance, **MUST** be provided.

NOTE: For details about the parameters of the electric heating function, see the nameplate on the unit.

Electronic Work



WARNING:

BEFORE PERFORMING ANY ELECTRICAL OR WIRING WORK, TURN OFF THE MAIN POWER TO THE SYSTEM.

Electronic Type

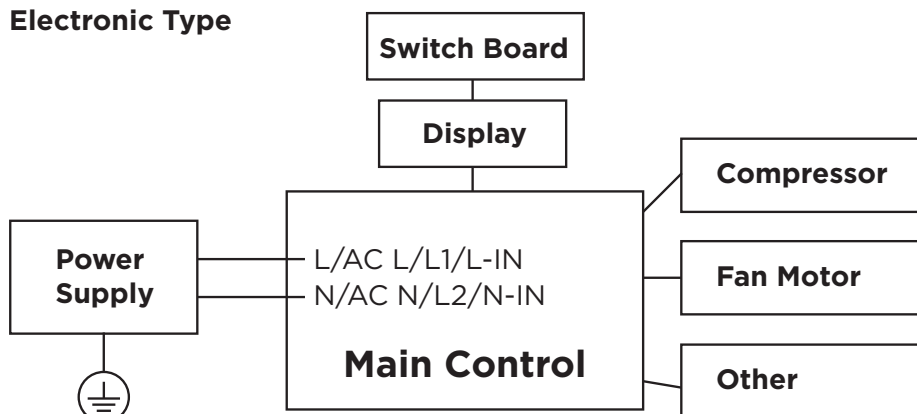

NOTE: Please strictly follow the wiring label attached to the machine for all wiring connections. The wiring diagram may vary for different units. Please refer to the wiring diagram on the machine you have purchased. The above wiring diagram is a simplified version for preliminary illustration purposes only.



A2L

CAUTION: Risk of fire flammable materials

IMPORTANT NOTE: Read this manual carefully before installing or operating your new appliance unit. Make sure to save this manual for future reference.

Explanation of symbols displayed on the unit

	CAUTION	This symbol shows that the operation manual should be read carefully.
	CAUTION	This symbol shows that a service personnel should be handling this equipment with reference to the installation manual.
	CAUTION	This symbol shows that information is available such as the operating manual or installation manual.

⚠ WARNING

- Servicing shall only be performed as recommended by the equipment manufacturer. Maintenance and repair requiring the assistance of other skilled personnel shall be carried out under the supervision of the person competent in the use of flammable refrigerants.
 - DO NOT modify the length of the power cord or use an extension cord to power the unit.
 - DO NOT share a single outlet with other electrical appliances. Improper power supply can cause fire or electrical shock.
 - Please follow the instructions carefully to handle, install, clear, and service the appliance to avoid any damage or hazard.
- Flammable
Refrigerant R32 is used within the appliance.
- When maintaining or disposing of the appliance, the refrigerant (R32) shall be recovered properly and shall not discharge to air directly.
 - Compliance with national gas regulations shall be observed.
 - Keep ventilation openings clear of obstruction.
 - The appliance shall be stored so as to prevent mechanical damage from occurring.
 - The appliance shall be stored in a well-ventilated area where the room size corresponds to the room area as specified for operation.
 - Any person who is involved with working on or breaking into a refrigerant circuit should hold a current, valid certificate from an industry-accredited assessment authority, which authorizes their competence to handle refrigerants safely in accordance with an industry-recognized assessment specification. All training shall follow the ANNEX HH requirements of UL 60335-2-40 4th Edition.

Examples for such working procedures are:

- breaking into the refrigerating circuit;
- opening of sealed components;
- opening of ventilated enclosures.

-No open fire or device like switch which may generate spark/arcing shall be around appliance to avoid causing ignition of the flammable refrigerant used.

Please follow the instructions carefully when storing or maintaining the appliance to prevent mechanical damage from occurring.

-Do not use means to accelerate the defrosting process or to clean, other than those recommended by the manufacturer.

-The appliance shall be stored in a room without continuously operating ignition sources (for example: open flames, an operating gas appliance) and ignition sources or (for example: an operating electric heater) close to the appliance.

-Do not pierce or burn.

-Be aware that the refrigerants may not contain an odor.

- No method other than that recommended by the manufacturer should be used to accelerate the defrosting process or for cleaning.
- The unit shall be stored in a room without continuously operating ignition sources (i.e., open flames, an operating gas appliance or an operating electric heater).
- Appliance should be installed, operated and stored in a room with a floor area according to the amount of refrigerant to be charged. For specific information on the type of gas and the amount, please refer to the relevant label on the unit itself.
- Appliance should be installed, operated and stored in a room with a floor area larger than 4 m²
- The appliance shall be stored in a room without continuously operating open flames (for example an operating gas appliance) and ignition sources (for example an operating electric heater).

1. Transport of equipment containing flammable refrigerants

See transport regulations.

2. Marking of equipment using signs

See local regulations.

3. Disposal of equipment using flammable refrigerants

See national regulations.

4. Storage of equipment/appliances

The storage of the appliance should be in accordance with the applicable regulations or instructions, whichever is more stringent.

5. Storage of packed (unsold) equipment

Storage package protection should be constructed such that mechanical damage to the equipment inside the package will not cause a leak of the refrigerant charge. The maximum number of pieces of equipment permitted to be stored together will be determined by local regulations.

6. Information on servicing

1) Checks to the area

Prior to beginning work on systems containing flammable refrigerants, safety checks are necessary to ensure that the risk of ignition is minimized. For repair to the refrigerating system, the following precautions shall be complied with prior to conducting work on the system.

- 2) Work procedure
Work shall be undertaken under a controlled procedure so as to minimize the risk of a flammable gas or vapour being present while the work is being performed.
- 3) General work area
All maintenance staff and others working in the local area shall be instructed on the nature of work being carried out. Work in confined spaces shall be avoided. The area around the workspace shall be sectioned off. Ensure that the conditions within the area have been made safe by control of flammable material.
- 4) Checking for presence of refrigerant
The area shall be checked with an appropriate refrigerating detector prior to and during work, to ensure the technician is aware of potentially flammable atmospheres. Ensure that the leak detection equipment being used is suitable for use with flammable refrigerants, i.e., non-sparking, adequately sealed or intrinsically safe.
- 5) Presence of fire extinguisher
If any hot work is to be conducted on the refrigeration equipment or any associated parts, appropriate fire extinguishing equipment shall be available to hand. Have a dry powder or CO₂ fire extinguisher adjacent to the charging area.
- 6) No ignition sources
No person carrying out work in relation to a refrigerating system which involves exposing any pipe work that contains or has contained flammable refrigerant shall use any sources of ignition in such a manner that it may lead to the risk of fire or explosion. All possible ignition sources, including cigarette smoking, should be kept sufficiently far away from the site of installation, repairing, removing and disposal, during which flammable refrigerant can possibly be released to the surrounding space. Prior to work taking place, the area around the equipment is to be surveyed to make sure that there are no flammable hazards or ignition risks. No Smoking signs shall be displayed.
- 7) ventilated area
Ensure that the area is in the open or that it is adequately ventilated before breaking into the system or conducting any hot work. A degree of ventilation shall continue during the period that the work is carried out. The ventilation should safely disperse any released refrigerant and preferably expel it externally into the atmosphere.
- 8) Checks to the refrigerating equipment
Where electrical components are being changed, they shall be fit for the purpose and to the correct specifications. At all times the manufacturer's maintenance and service guidelines shall be followed. If in doubt consult the manufacturer's technical department for assistance. The following checks shall be applied to installations using flammable refrigerants: the actual refrigerant charge is in accordance with the room size within which the refrigerant containing parts are installed; the ventilation machinery and outlets are operating adequately and are not obstructed; if an indirect refrigerating circuit is being used, the secondary circuit shall be checked for the presence of refrigerant; marking to the equipment continues to be visible and legible. Markings and signs that are illegible shall be corrected; and refrigerating pipe or components are installed in a position where

they are unlikely to be exposed to any substance which may corrode refrigerant containing components, unless the components are constructed of materials which are inherently resistant to being corroded or are suitably protected against being so corroded.

9) Checks to electrical devices

Repair and maintenance to electrical components shall include initial safety checks and component inspection procedures. If a fault exists that could compromise safety, then no electrical supply shall be connected to the circuit until it is satisfactorily dealt with. If the fault cannot be corrected immediately but it is necessary to continue operation, an adequate temporary solution shall be used. This shall be reported to the owner of the equipment so all parties are advised. Initial safety checks shall include:

That capacitors are discharged: this shall be done in a safe manner to avoid possibility of sparking; that there no live electrical components and wiring are exposed while charging, recovering or purging the system; that there is continuity of earth bonding.

7. Sealed electrical components shall be replaced.

8. Intrinsically safe components must be replaced.

9. Cabling

Check that cabling will not be subject to wear, corrosion, excessive pressure, vibration, sharp edges or any other adverse environmental effects. The check shall also take into account the effects of aging or continual vibration from sources such as compressors or fans.

10. Detection of flammable refrigerants

Under no circumstances shall potential sources of ignition be used in the searching for or detection of refrigerant leaks. A halide torch (or any other detector using a naked flame) shall not be used.

The following leak detection methods are deemed acceptable for systems containing flammable refrigerants. Electronic leak detectors shall be used to detect flammable refrigerants, but the sensitivity may not be adequate, or may need re-calibration. (Detection equipment shall be calibrated in a refrigerant-free area.) Ensure that the detector is not a potential source of ignition and is suitable for the refrigerant used. Leak detection equipment shall be set at a percentage of the LFL of the refrigerant and shall be calibrated to the refrigerant employed and the appropriate percentage of gas (25% maximum) is confirmed. Leak detection fluids are suitable for use with most refrigerants but the use of detergents containing chlorine shall be avoided as the chlorine may react with the refrigerant and corrode the copper pipe-work. If a leak is suspected, all naked flames shall be removed/extinguished. If a leakage of refrigerant is found which requires brazing, all of the refrigerant shall be recovered from the system, or isolated (by means of shut off valves) in a part of the system remote from the leak. Removal of refrigerant shall be according to Removal and evacuation.

11. Removal and evacuation

When breaking into the refrigerant circuit to make repairs—or for any other purpose - conventional procedures shall be used. However, for flammable refrigerants it is important that best practice be followed, since flammability is a consideration. The following procedure shall be adhered to:

- Safely remove refrigerant following local and national regulations;
- Evacuate;
- Purge the circuit with inert gas (optional for A2L);
- Evacuate (optional for A2L);
- continuously flush or purge with inert gas when using flame to open circuit; and
- open the circuit.

The refrigerant charge shall be recovered into the correct recovery cylinders if venting is not allowed by local and national codes. For appliances containing flammable refrigerants, the system shall be purged with oxygen-free nitrogen to render the appliance safe for flammable refrigerants. This process might need to be repeated several times. Compressed air or oxygen shall not be used for purging refrigerant systems. For appliances containing flammable refrigerants, refrigerants purging shall be achieved by breaking the vacuum in the system with oxygen-free nitrogen and continuing to fill until the working pressure is achieved, then venting to atmosphere, and finally pulling down to a vacuum (optional for A2L). This process shall be repeated until no refrigerant is within the system (optional for A2L). When the final oxygen-free nitrogen charge is used. The system shall be vented down to atmospheric pressure to enable work to take place. The outlet for the vacuum pump shall not be close to any potential ignition sources, and ventilation shall be available.

12. Charging procedures

In addition to conventional charging procedures, the following requirements shall be followed. Ensure that contamination of different refrigerants does not occur when using charging equipment. Hoses or lines shall be as short as possible to minimize the amount of refrigerant contained in them. Cylinders shall be kept in an appropriate position according to the instructions. Ensure that the refrigeration system is earthed prior to charging the system with refrigerant. Label the system when charging is complete (if not already). Extreme care shall be taken not to overfill the refrigeration system. Prior to recharging the system, it shall be pressure tested with OFN. The system shall be leak tested on completion charging but prior to commissioning. A follow up leak test shall be carried out prior to leaving the site.

13. Decommissioning

Before carrying out this procedure, it is essential that the technician is completely familiar with the equipment and all its detail. It is recommended good practice that all refrigerants are recovered safely. Prior to the task being carried out, an oil and refrigerant sample shall be taken in case analysis is required prior to re-use of reclaimed refrigerant. It is essential that electrical power is available before the task is commenced.

- a) Become familiar with the equipment and its operation.
- b) Isolate system electrically.
- c) Before attempting the procedure ensure that: mechanical handling equipment is available, if required, for handling refrigerant cylinders; all personal protective equipment is available and being used correctly; the recovery process is supervised at all times by a competent person; recovery equipment and cylinders conform to the appropriate standards.
- d) Pump down refrigerant system, if possible.

- e) If a vacuum is not possible, make a manifold so that refrigerant can be removed from various parts of the system.
- f) Make sure that cylinder is situated on the scales before recovery takes place.
- g) Start the recovery machine and operate in accordance with instructions.
- h) Do not overfill cylinders. (No more than 80% volume liquid charge.)
- i) Do not exceed the maximum working pressure of the cylinder, even temporarily.
- j) When the cylinders have been filled correctly and the process completed, make sure that the cylinders and the equipment are removed from site promptly and all isolation valves on the equipment are closed off.
- k) Recovered refrigerant shall not be charged into another refrigeration system unless it has been cleaned and checked.

14. Labelling

Equipment shall be labelled stating that it has been de-commissioned and emptied of refrigerant. The label shall be dated and signed. Ensure that there are labels on the equipment stating the equipment contains flammable refrigerant.

15. Recovery

When removing refrigerant from a system, either for servicing or decommissioning, it is recommended good practice that all refrigerants are removed safely. When transferring refrigerant into cylinders, ensure that only appropriate refrigerant recovery cylinders are employed. Ensure that the correct number of cylinders for holding the total system charge is available. All cylinders to be used are designated for the recovered refrigerant and labelled for that refrigerant (i.e., special cylinders for the recovery of refrigerant). Cylinders shall be complete with pressure-relief valve and associated shut-off valves in good working order. Empty recovery cylinders are evacuated and, if possible, cooled before recovery occurs. The recovery equipment shall be in good working order with a set of instructions concerning the equipment that is at hand and shall be suitable for the recovery of the flammable refrigerant. If in doubt, the manufacturer should be consulted. In addition, a set of calibrated weighing scales shall be available and in good working order. Hoses shall be complete with leak-free disconnect couplings and in good condition. The recovered refrigerant shall be processed according to local legislation in the correct recovery cylinder, and the relevant waste transfer note arranged. Do not mix refrigerants in recovery units and especially not in cylinders. If compressors or compressor oils are to be removed, ensure that they have been evacuated to an acceptable level to make certain that flammable refrigerant does not remain within the lubricant. The compressor body shall not be heated by an open flame or other ignition sources to accelerate this process. When oil is drained from a system, it shall be carried out safely.

Before You Get Started

Accessories

What is in the Package

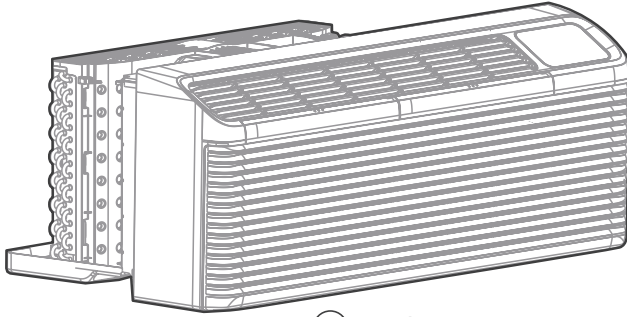

① Unit

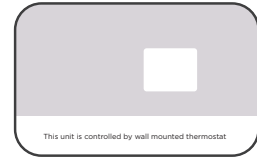

② Control panel sticker

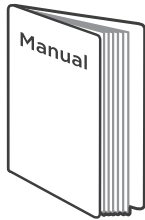

③ Owner's manual

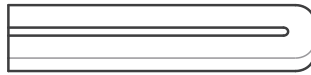

④ Sponge A

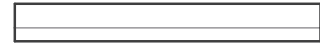

⑤ Sponge B * 2



⑥ Screws* 4
(for installing the wall sleeve)

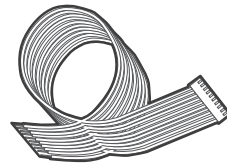

⑦ Cable (optional)

What you need to purchase

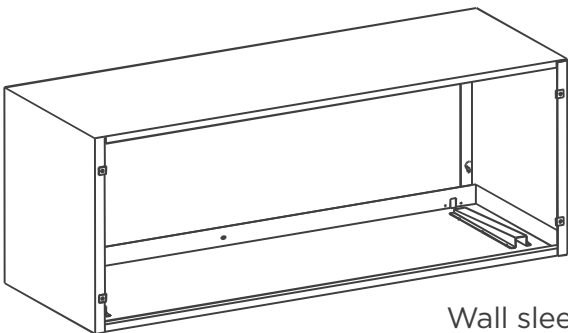

Wall sleeve

(Not Included)

Prepare the following tools



Gloves



Screwdriver



Pencil



Drill

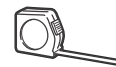

Ruler or tape measure



Level

(Not Included)

Installation Overview

NOTE ON ILLUSTRATIONS:

Illustrations in this manual are for explanatory purposes. The actual shape of your unit may be slightly different. The actual shape shall prevail.

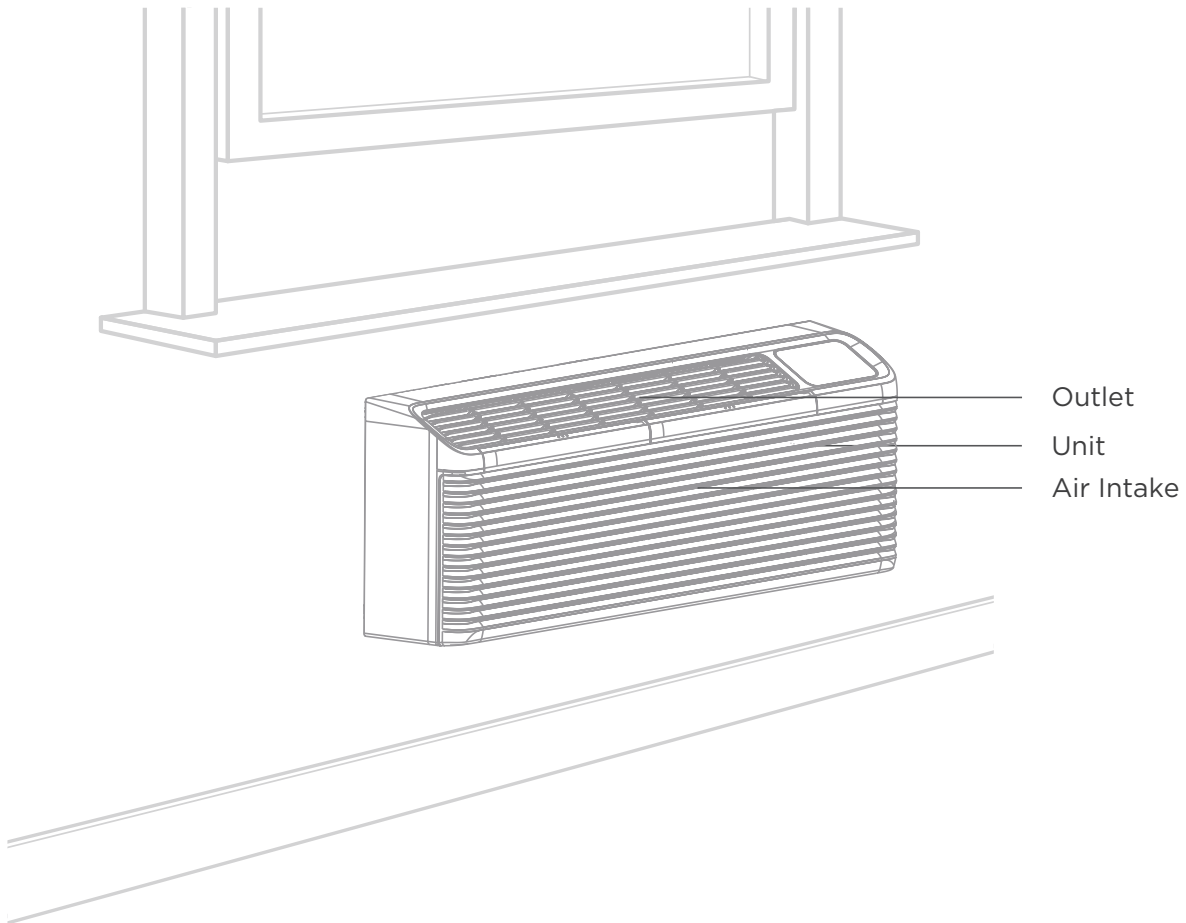

Product Installation

1 Preparing for Installation

⚠ CAUTION

- There are sharp edges that can cause serious cuts.
- When lifting the air conditioner, it is HEAVY. Use 2 people to lift.

Installation size confirmation:

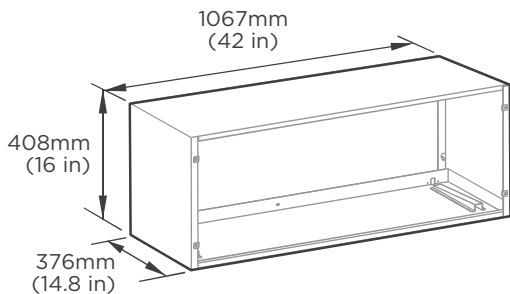

Wall sleeve size requirements (wall hole size should refer to the wall sleeve size)

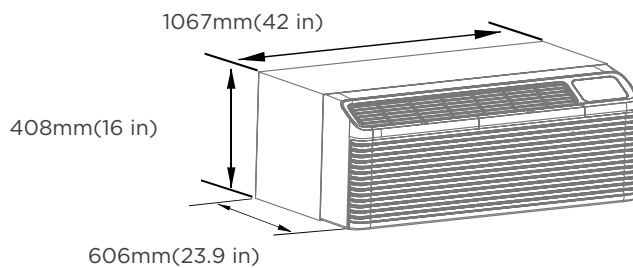

Product size

Confirmation of installation position :

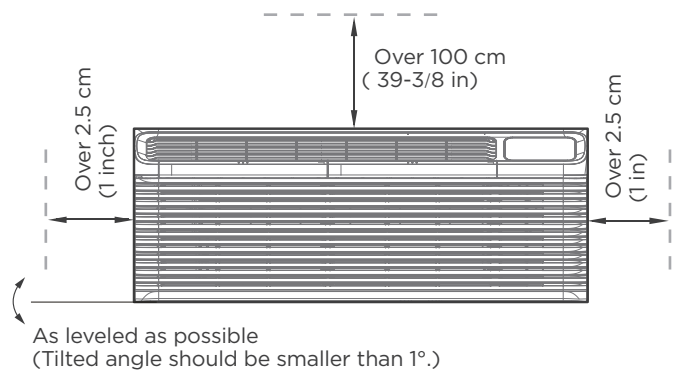
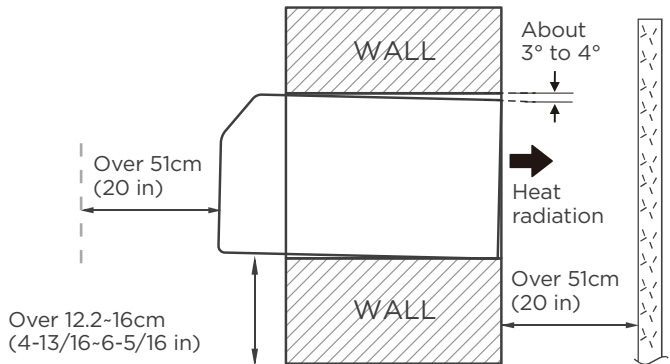

- For the existing sleeve, you should measure the wall sleeve dimensions.
- Install the new air conditioner according to these installation instructions to achieve the best performance. All wall sleeves used to mount the new air conditioner must be in good structural condition and have a rear grille that securely attaches to the sleeve or the flange of the sleeve to secure the new air conditioner.
- To avoid vibration and noise, make sure the unit is installed securely and firmly.
- When installing the sleeve, make certain there is nothing within 20 inches of the back that would interfere with heat radiation and exhaust air flow.

NOTE: To make the appliance work better, please do not place a barrier in the air outlet.

Step 1: Attach sponge A to the wall sleeve.

- If using the old wall sleeve, the sponge on the wall sleeve needs to be replaced. First, remove the old sponge from the sleeve, then attach sponge A from the accessories. (See Fig. 1.)
- If using the new wall sleeve, simply attach sponge A. (See Fig. 1.)

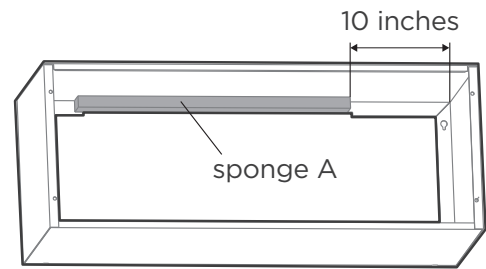

Fig. 1

Step 2: Attach the wall sleeve (if any).

Refer to the installation instruction of sleeve assembly for details. To avoid vibration and noise, make sure the wall sleeve is installed securely and firmly. (See Fig. 2.)

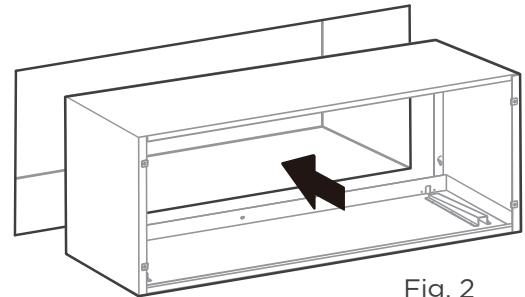

Fig. 2

Step 3: Remove the front panel.

1. Pull out at the bottom to release it from the tabs.
2. lift the front panel up. (See Fig. 3.)

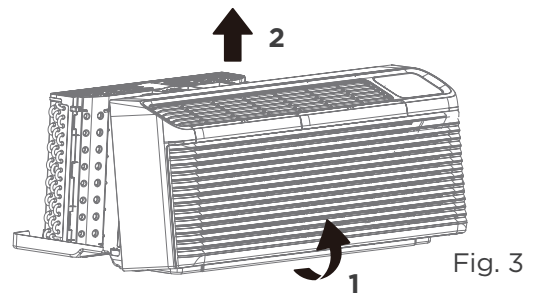

Fig. 3

Step 4: Open and close the vent door (if needed).

- Remove the 2 shipping screws and the metal cover plate to open the vent door. (See Fig. 4.)
- Reinstall the metal cover plate to close the vent door.

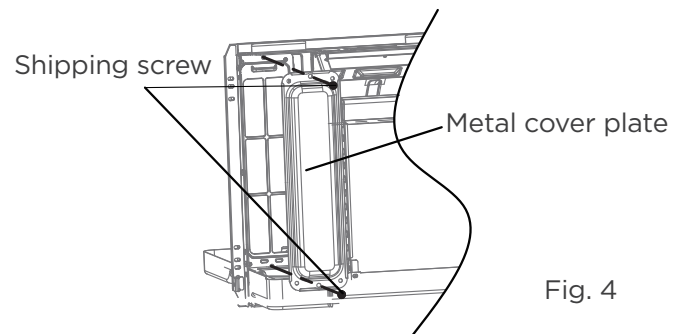

Fig. 4

**NOTE:**

The metal cover plate should be properly stored when removed. It needs to be reinstalled to close the vent door.

NOTE: When the metal cover plate is removed, some outdoor air will be drawn into the room. This will reduce heating or cooling efficiency.

Step 5: Attach sponge B to the rear panel.

If using the old rear grille, remove the sponge from the rear grille, then attach Sponge B to the machine's rear panel. (See Fig. 5.)

If using the new rear grille, do not attach any sponge to the rear grille; attach Sponge B to the machine's rear panel. (See Fig. 5.)

Align the two sponge strips with the left and right edges of the rear panel respectively, then adhere them.

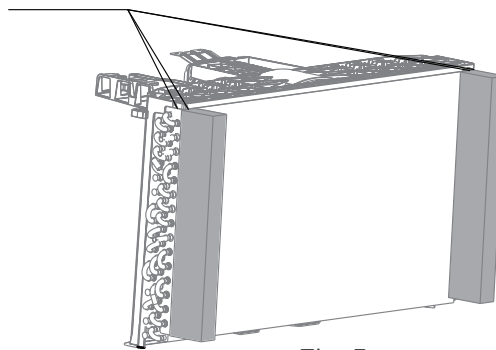

Fig. 5

Step 6: Install the unit.

Lift the unit level and slide unit into the wall sleeve until firmly against the front of wall sleeve and secure with 4 screws and washers (supplied in the SLEEVE ASSEMBLY) through the unit flange holes. (See Fig. 6 and Fig. 7.)

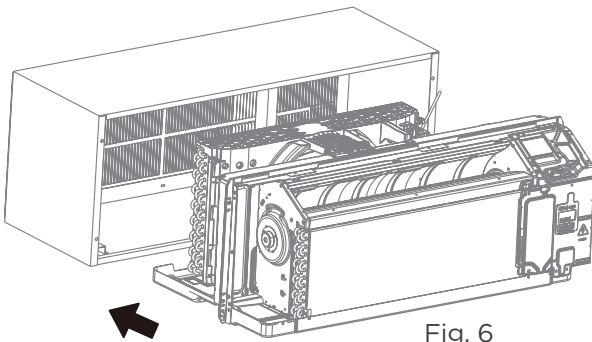

Fig. 6

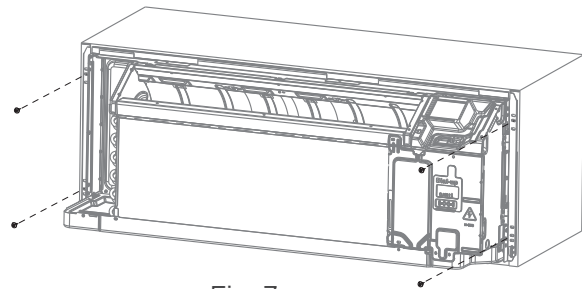

Fig. 7

Step 7: Install the front panel.

1. Place tabs over the top rail.
2. Push inward at the bottom until the panel snaps into place.

(See Fig. 8.)

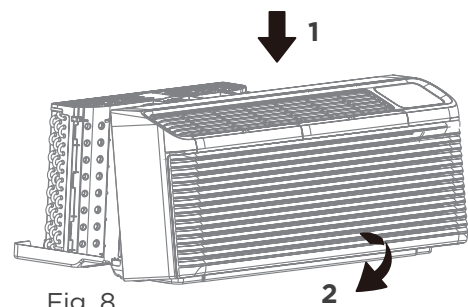

Fig. 8

⚠ CAUTION

- Do not put obstacles around the air inlet or outlet of the unit, such as window curtain etc.
- Always insert the filter securely, clean the filter once every 3 months, as required.

DIP Switch Configurations

⚠ CAUTION

Unit must be powered off to effectively change the DIP switch configuration.

Removing the front panel

Step 1: Pull out at the bottom to release it from the tabs, then lift the front panel up. See Fig. 9.

Step 2: Remove the rubber grommet to set the DIP switches. Reinstall the rubber grommet after you finish. Do not discard the rubber grommet. See Fig. 10.

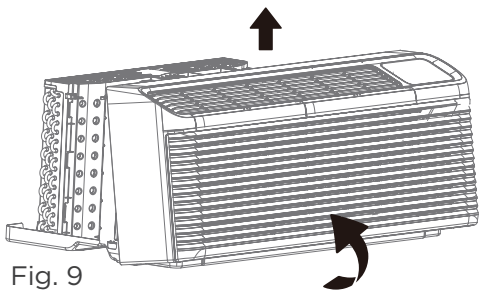

Fig. 9

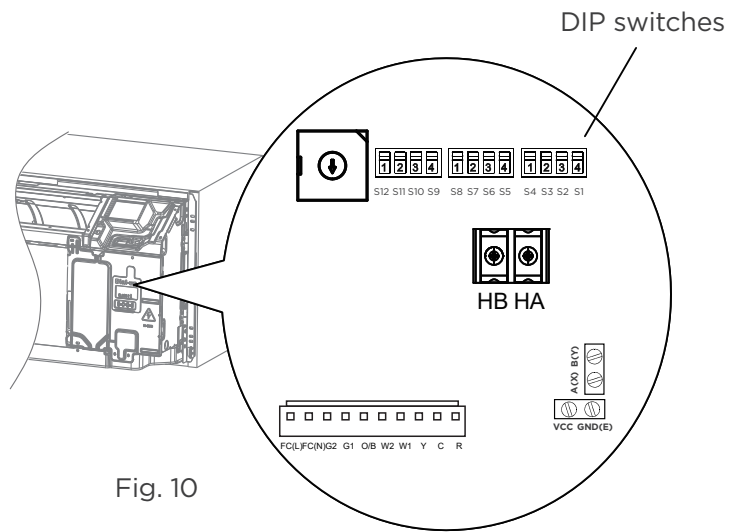

Fig. 10

DIP SWITCH CONFIGURATIONS

- See Table 1 (on the next page) and Fig. 11 for DIP Switches configurations and functions of each DIP switch position.

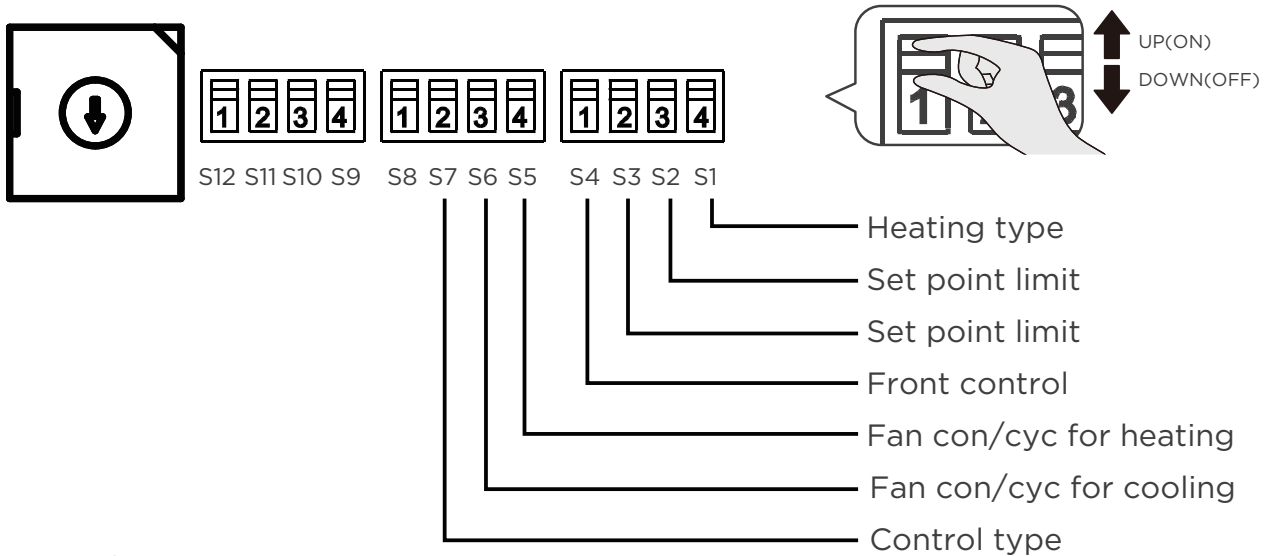

Fig. 11

Table 1— DIP SWITCHES CONFIGURATIONS

Dip Switch	Up(ON)-1	Down(OFF)-0
S1	Heating Mode with Only Electric Heating	Heating Mode with Both Electric Heating and Heat Pump Heating
S2 S3	Setting Temperature Range: S2=OFF, S3=OFF: 60°F-86°F; S2=OFF, S3=ON: 63°F-80°F; S2=ON, S3=OFF: 65°F-78°F; S2=ON, S3=ON: 68°F-75°F.	
S4	1 (Turn Off Front Control) ON	0 (Turn On Front Control) OF
S5	In Heating Mode, When the Indoor Fan Continuous Operation is Enabled.	In Heating Mode, When the Indoor Fan Continuous Operation is Disabled
S6	In Cooling Mode, When the Indoor Fan Continuous Operation is Enabled.	In Cooling Mode, When the Indoor Fan Continuous Operation is Disabled.
S7	Wall thermostat control	The display panel and wall thermostat control simultaneously

Electric Heat Only (for heat pump unit only)

This setting is typically used for Emergency Heating.

Setpoint Temperature Limits

Provides a restricted range of temperature control.

Heat and Cool Fan CON/CYC DIP Switch

Allows the fan to operate in continuous or cycle modes while the unit is in heating and cooling mode.

CON(Continuous)

Allows the fan to run continuously, circulating air even when the temperature setting has been satisfied. This switch helps to maintain the room temperature closer to the thermostat setting.

CYC(Cycle)

This setting allows the fan to cycle on and off with the compressor or electric heater. The fan stops a short time after the temperature setting is satisfied.

Wall Thermostat control

A wall thermostat can be connected to the unit. If the DIP switch is set to ON, when the air conditioner is controlled by the thermostat, it will only process inputs from the thermostat. Inputs from the panel, remote control, etc., will be invalid. If the DIP switch is set to OFF, the air conditioner can be controlled by the panel, remote control, and thermostat together. When the thermostat outputs a control signal to the air conditioner, the air conditioner will prioritize the input from the thermostat.

DIP Switch Configurations by Panel Control (optional)

⚠ CAUTION

The unit must be in stand-by status to effectively change the DIP switch configuration by panel.

- Press the up and down buttons together for 3 seconds to activate the DIP switch configurations via panel control. (See Fig. 12.)

- See Table 2 for Dip Switches configurations and functions via panel control.

NOTE: Press the up and down buttons together for 3 seconds again, or no operation within 30 seconds to exit the DIP switch configurations via panel control, and the unit will save the last settings.

- The LED will display Sx, Fx, (x could be 1, 2, 3, etc.) and other letters, such as ON, OF, HY, EH, etc., used to indicate the current function serial number and function switch status. (See Fig. 12.)

- Press the up button to adjust the DIP switch serial number, press the down button to adjust the function switch corresponding to that serial number.

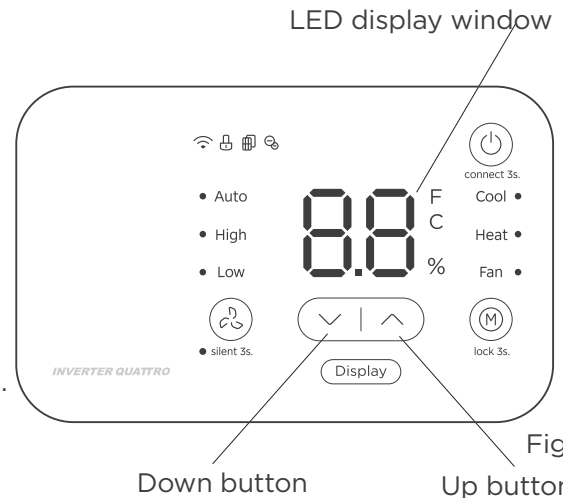

Fig. 12

Table 2 - DIP SWITCHES CONFIGURATIONS

Aux Display	Dip Switch	Up(ON)-1	Down(OFF)-0
S0	\	1 (Settings via Panel are Valid), LED Display AC	0 (Settings via Dip Switch Panel are Valid, Query Only) LED Display DP
S1	S1	Heating Mode with Only Electric Heating. LED Display EH	Heating Mode with Both Electric Heating and Heat Pump Heating. LED Display HY
S2 Display Lower Temperature Limit S3 Display Upper Temperature Limit	S2 S3	Setting Temperature Range: S2=OFF, S3=OFF: 60°F-86°F; S2=OFF, S3=ON: 63°F-80°F; S2=ON, S3=OFF: 65°F-78°F; S2=ON, S3=ON: 68°F-75°F.	
S4	S4	1 (Turn Off Front Control) On	0 (Turn On Front Control) OF
S5	S5	In Heating Mode, When the Indoor Fan Continuous Operation is Enabled. LED Display On	In Heating Mode, When the Indoor Fan Continuous Operation is Disabled. LED Display OF
S6	S6	In Cooling Mode, When the Indoor Fan Continuous Operation is Enabled. LED display On	In Cooling Mode, When the Indoor Fan Continuous Operation is Disabled. LED displays OF
S7	S7	Wall thermostat control. LED display TH	The display panel and wall thermostat control simultaneously. LED display HY.
F1	\	Select the fresh air or ERV fan speed under air conditioning control. Au means Auto. 80 means high. 60 means medium. 40 means low. OF means off. (optional)	
F2	\	Smart humidity control settings: 40-60, automatic Au, off OF. Needs to be activated under the shutdown of cooling.	

Table 2 - DIP SWITCHES CONFIGURATIONS

F3	\	Negative ions (optional) : “On” means the function is on, OF means the function is off.
F4	\	Set low temperature protection point: 0-16 degrees Celsius or corresponding Fahrenheit degrees, OF means off.
F5	\	Set high temperature protection point: 30-37 degrees Celsius or corresponding Fahrenheit degrees, OF means off.

NOTE:

1. If S0 is selected as AC, that is, the switch for the air conditioning panel control, you need to refer to the previous section “Dip switch configurations” and adjust the DIP switch S4 to OFF. By doing this, the functional status displayed on the S4 channel of the air conditioning panel will take effect.
2. After all is set, press the up and down buttons together for 3 seconds to exit the operation interface and cut off the power. When re-powered on, the settings are activated.
3. When S0 is selected as DP, the functional status displayed for S0-S7 can only be viewed and cannot be adjusted using the down button.
4. If no negative ions are present, skip F3. If a 24V wire controller control is selected, S5 and S6 will be skipped. If the dial plate is not connected, S4 will be skipped. If there is no fresh air module, F1 will be skipped.
5. Negative ions function (optional): when the function is on, the ion generator is energized and will help to remove pollen and impurities from the air and trap them in the filter.
6. Low temperature protection: when the indoor temperature abnormally decreases (below the set threshold), it automatically triggers a protection mechanism to prevent the equipment from operating under overcooling or the ambient temperature from continuously being too low.
7. High temperature protection: when the indoor temperature abnormally increases (above the set threshold), it automatically triggers a protection mechanism to prevent the equipment from overheating or the ambient temperature from continuously being too high.

Wall Thermostat Terminal (optional)

IMPORTANT

Only trained, qualified personnel should access the electrical panel on the unit and install electrical accessories. Please contact your local electrical contractor, dealer, or distributor for assistance.

Step 1: Thermostat Wire Routing

Thermostat wire is field-supplied. Recommended wire gauge is 18-to 20-gauge solid thermostat wire.

NOTE: It is recommended that extra wires BE run to the unit in case any are damaged during installation. Thermostat wire should always be routed around or under, NEVER through, the wall sleeve. The wire should then be routed behind the front panel to the easily accessible terminal connector. (See Fig. 13.)

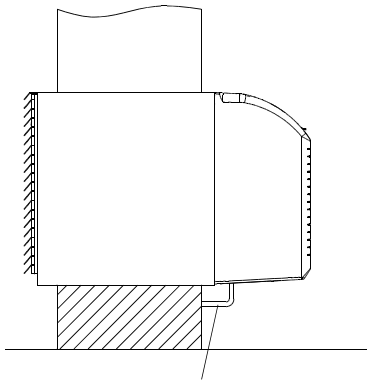

THE THERMOSTAT WIRE ROUTING
(UNDER SLEEVE, BEHIND FRONT PANEL)

Fig. 13 - Proper Wire Routing Beneath Unit

NOTE: Refer to thermostat installation instructions for details on installing the wall thermostat.

Step 2: Installation instructions for some types of wall thermostat (you can consult with the sales agency or manufacturer for details)

Remove 5 screws as shown below and take the cover panel down.

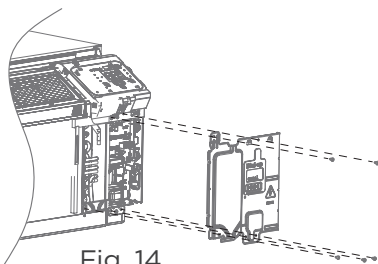
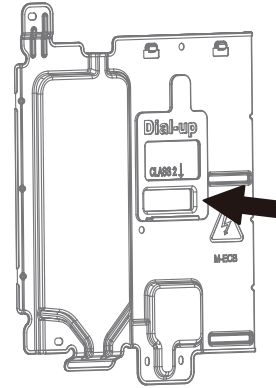

Fig. 14

CAUTION: It is very important to retighten these five screws after completion.



CAUTION:

If you need to route the wire out through the fireproof sheet-metal area, you may remove the rubber grommet, pierce it at the required spot, and then reinstall it. Do not discard the rubber grommet.

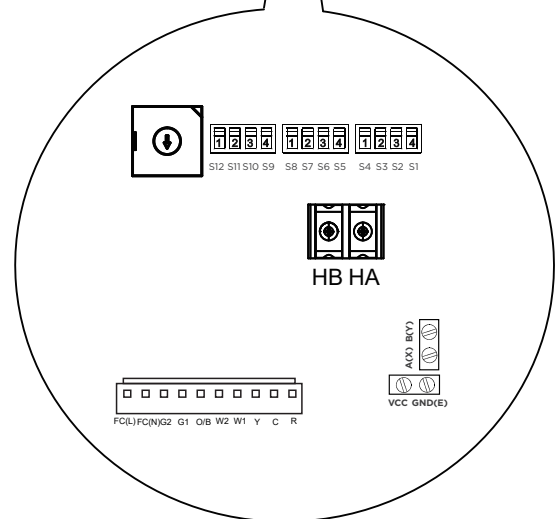
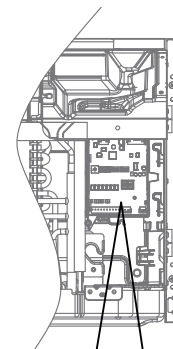
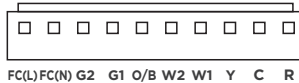

Fig. 15

1. Wall Thermostat (24V AC) (optional)

Terminal of PTAC other Wall Thermostat

MODE A (optional)



MODE B (optional)



TERMINAL	DESIGNATION	MODE A Wire color
FC(L)	Front desk control terminal L	Brown
FC(N)	Front desk control terminal N	Pink
G2	Low fan speed	Purple
G1	High fan speed	Green
O/B	4-way valve; Reverse cycle (Energized in Heat) For heat pump models	Blue
W2	Electrical heater 2	White
W1	Electrical heater 1	White
Y	Compressor	Yellow
C	24V AC terminal N (Neutral), Common	Black
R	24V AC terminal L	Red

2. NON-POLARITY WIRED CONTROLLER (optional)

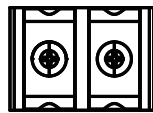

HB HA

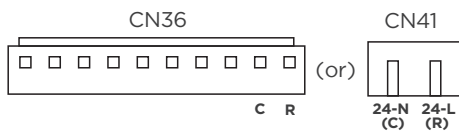

HA	COMMUNICATION	NON-POLARITY WIRED CONTROLLER
HB		
R	24V AC	
C		

Network address is configured via DIP switch F1 and the rotary switch. The corresponding address assignment is as follows:

S12	S11	Base Address
OFF	OFF	0
OFF	ON	16
ON	OFF	32
ON	ON	48

3. Wired Controller (12V) (optional)

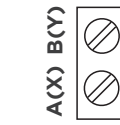

VCC	12V, RS485 wired controller
GND	
A	
B	

4. CCM(optional)

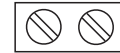
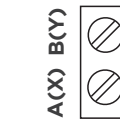

E	RS485 CCM
X	
Y	

Network address is configured via DIP switch F1 and the rotary switch. The corresponding address assignment is as follows:

S12	S11	Base Address
OFF	OFF	0
OFF	ON	16
ON	OFF	32
ON	ON	48

CAUTION

UNIT DAMAGE HAZARD

- Failure to follow this caution may result in equipment damage or improper operation.
- Improper wiring may damage the unit's electronics. Common bussing is not permitted. Damage or erratic operation may result.

NOTE:

- Use terminal 4-way for heat pump connection only.
- The wall thermostat must be a heating changeover 4-way valve.
- For thermostats that have only one fan speed output (on or auto), the fan speed is determined by how the terminal connector is wired. If a Low fan is desired, wire the G output from the thermostat to (G2) on the unit's terminal block. If a High fan is desired, wire the G output from the thermostat to (G1) on the unit's terminal block.
- The range of the set temperature of the wall thermostat must align with the range of the DIP switch setting.
- The wall thermostat must be set according to the proper unit type: heat pump or no heat pump.
- When O/B and W1; O/B and W2; or O/B and both W1 and W2 signals are present, the air conditioner will automatically manage heating via the heat pump and electric heat. The air conditioner has two electric heating input terminals, W1 and W2. If only one of W1 or W2 is energized, the unit will only turn on the high-stage electric heat (if equipped). If both W1 and W2 are energized simultaneously, the activation of electric heating is controlled by the air conditioner itself.
- If the S7 is set to simultaneous control by the wall thermostat and the display panel, then when the terminal signal input is correct, the LED will display LC.
- Please do not remove the control panel.

FRONT DESK CONTROL

The controller can handle a switch signal from FC(L) and FC(N) inputs, called front desk control. Input must be 24VAC. If the system doesn't receive a 24VAC signal, it will turn off; otherwise, the unit runs in normal control. The DIP switch can control the FRONT DESK CONTROL feature. If the DIP switch is in the DOWN position, the unit will be turned off; otherwise, the unit runs in normal control.

Operation Instructions

Control Panel

NOTE:

The control panel keypad will look like the following Fig. 16. For some models with REMOTE SIGNAL RECEPTOR, the unit can be controlled by the control panel alone or by the remote. NOTE: Some models have no REMOTE SIGNAL RECEPTOR.

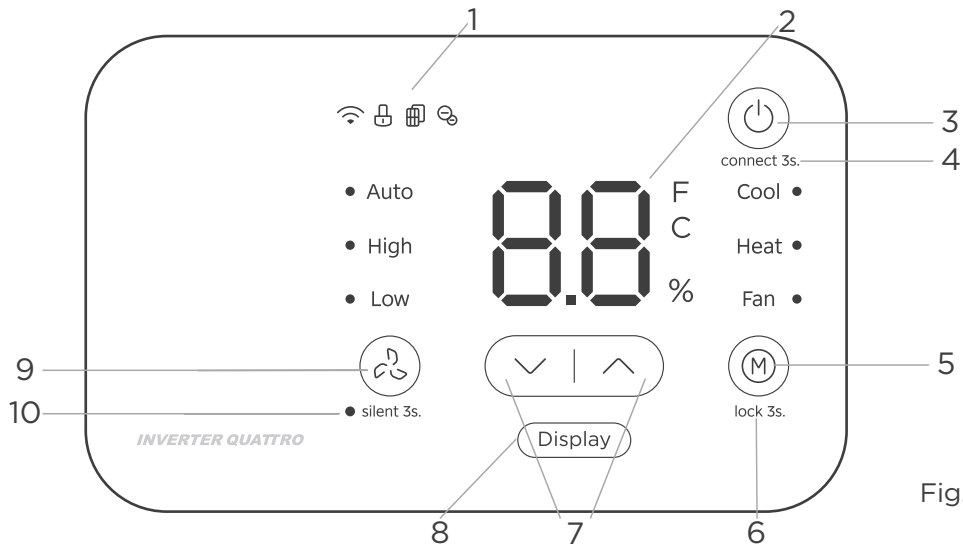





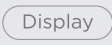



Fig. 16

		Description
1	Lock Icon	Icon appears to indicate that the panel lock has been turned on
	Check Filter Icon	Icon appears to indicate that the air filter needs to be cleaned.
	Connect Icon (optional)	Icon appears to indicate that the wireless module has been activated.
	Negative Ion Icon (optional)	Icon appears to indicate that the negative ion function has been activated.
2	<p>Display</p>	<p>Shows the set temperature in°C or °F. While on Fan only mode, it shows the room temperature.</p> <p>Control code (on some models): LC - Pads on the control panel are not available. The unit can be set by using the wire controller only. FC - Pads on the control panel and the wire controller are not available. The unit can be set by using FRONT DESK CONTROL only.</p> <p>Error codes: The unit may stop operating due to a malfunction with the unit. If this occurs, an error code may appear on the display like below. Wait 10 minutes as the problem may resolve itself. If not, disconnect the power, then connect it again. Turn the unit on. If the problem persists, disconnect the power and contact customer service. Error codes appear and begin with the letters as noted below in the window display of the indoor unit: EH(xx), EL(xx), EC(xx), PH(xx), PL(xx), PC(xx). NOTE: When error occurs,unplug the unit and plug it back in. If error repeats, call for service.</p> <p>Other codes: LO - Room temperature is lower than 0°C/32°F; HI - Room temperature is higher than 37°C/99°F; FP - Low temperature protection. HP- High temperature protection. NOTE: All the illustrations in this manual are for explanatory purposes only. Your air conditioner may be slightly different. The actual shape shall prevail.</p>

		Description
3	 Power - Function	<ul style="list-style-type: none"> · Press the POWER button to turn the unit on or off.
4	 <small>connect 3s.</small> Wireless connection (optional)	<ul style="list-style-type: none"> · To connect your air conditioner to wireless , press the power button for 3 seconds to initiate the wireless connection mode. The display shows 'AP' to indicate the unit is in the wireless connection mode. Refer to the wireless section for further instructions. · If connection is successful within 8 minutes, the unit will exit wireless connection mode automatically and the connect LED will illuminate. · If connection fails within 8 minutes, the unit exits wireless connection mode automatically and the connect LED will not illuminate. · After wireless connection is successful, you can press and hold the power and Down buttons for 3 seconds to turn off the wireless function and the LED display will show 'OF' for 3 seconds. Press the power and up buttons for 3 seconds to turn the wireless function back on and the LED display will show 'On' for 3 seconds.
5	 Mode - Function	<ul style="list-style-type: none"> · Push this button to cycle through the modes from Cool-Heat-FAN-Cool. The indicator light beside the "MODE" option will illuminate, identifying the mode selected. <p>To operate in Cool mode : Choose Cool Mode to set the cooling function. Use the Up (^) and Down (v) buttons to choose the desired temperature. When Cool Mode is selected, the fan speed can be adjusted by pressing the fan button.</p> <p>To operate in FAN Only Use this function only when cooling is not desired. You can choose any fan speed you prefer.</p> <p>During this function, the display will show the actual room temperature, not the set temperature, as in the cooling mode.</p> <p>In Fan Only mode, the set temperature cannot be adjusted.</p> <p>To operate in Heat mode (not suitable for cooling-only models): Choose Heat mode to set the heating function. Use the Up and Down buttons to choose the desired temperature .When heat Mode is selected, the fan speed can be adjusted by pressing the fan button.</p> <p>NOTE: The reverse cycle and electric heater cannot be run at the same time. In the following cases, it is normal that the reverse cycle does not operate.</p> <p>NOTE: If the unit has a DIP SWITCH feature, the temperature range is controlled by the DIP switch. See DIP SWITCH CONFIGURATIONS for details.</p>
6	 <small>lock 3s</small> Panel locking - Function	<ul style="list-style-type: none"> · Pressing the mode button for 3 seconds will turn on or off the lock panel function. The remote control still works. The panel locking indicator turns on when you lock the control panel. <p>NOTE: When the control panel is locked, pressing any other keys will make the panel locking indicator flash for 3 seconds.</p>

		Description
7	 Up and down buttons	<ul style="list-style-type: none"> · Push the UP (or DOWN) button to increase (or decrease) the set temperature of the unit in cooling or heating mode. The temperature can be set by increments of 1°C (1°F). The setting temperature appears in the display. NOTE: When the machine is turned on, press and hold “∨” and “∧” buttons together for 3 seconds will alternate the temperature display between °C & °F scales.
8	 Display button	<p>Press the Display button to turn the LED display on and off, which creates a comfortable environment.</p> <p>Pressing the Display button for 3 seconds will reset the filter clean indicator. This feature is a reminder to clean the air filter for normal operation. The filter indicator will illuminate after 250 hours of operation.</p>
9	 Fan (fan speed) - Function	<ul style="list-style-type: none"> · Every time you push this button, the fan speed cycles through the settings as follows: AUTO-HIGH-LOW-AUTO.
10	 <small>silent 3s.</small> Silent- Function (optional)	<ul style="list-style-type: none"> · Pressing the Fan button for 3 seconds will turn on or off the silent function. The fan will run at the silent setting.

Accessories

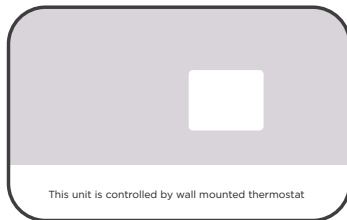

Control panel sticker

NOTE: When the unit displays LC, the Pads on the control panel are not available. The unit can be set up by using the wired controller only. You can install the accessory on the control panel.

NOTE: For some models, there is a corresponding operation that happens after 3 seconds when pressing any button.

NOTE: When there are wide differences between the USERS MANUAL and the Remote controller Illustration on function description, the description in the USERS MANUAL shall prevail.

App Setup and Operation (optional)

Wireless Control Feature

Applicable system: iOS, Android

- Please keep your app up to date with the latest version.
- Not all of Android and iOS systems are compatible with the app. We declare explicitly that we will not be held responsible for any issue as a result of the incompatibility.

Wireless safety strategy

- Smart Kit only supports WPA-PSK/WPA2-PSK encryption and no encryption. WPA-PSK/WPA2-PSK encryption is recommended.

NOTICE:

- Network issues may occasionally cause timeouts. The unit display and the app may become unsynchronized but this will resolve itself when the network is restored.
- Smart phone cameras need to be 5 megapixels or above to scan the QR code correctly.
- Should the network remain unavailable, it might be necessary to run the configuration process again.
- The app is subject to updates without prior notice for product function improvement.
- The actual network configuration process may vary slightly from the manual.
- Please check the service website for more information.

SPECIFICATION:

- Wireless Module Model: EU-SK105, US-SK105, EU-SK106, US-SK106, EU-SK107, US-SK107, EU-SK109, US-SK109, EU-SK110, US-SK110
- Antenna Type: Printed PCB Antenna
- Frequency Band: 2400 - 2483.5MHz
- Operation Temperature: 0°C-45°C/32°F-113°F
- Operation Humidity: 10% ~ 85%
- Power Input: DC 5V / 500mA
- Maximum TX Power: < 20dBm

PREPARATION

- Please ensure your mobile device is connected to your wireless router. The wireless router should already be connected to the Internet before doing user registration and network configuration.
- Preferably remove unneeded wireless networks on your phone to avoid problems during the configuration process.

Download and install the app

1. Ensure your mobile phone is connected to your home network.
2. Scan the QR code below to download the SmartHome app from app store or search for it directly on the Google Play Store or Apple's App Store.



Network configuration

NOTICE:

- As mentioned above, remove or “forget” other unneeded wireless networks especially if nearby. Your device should be connected to the same network you will be connecting the unit to.
- As your phone will temporarily connect to the air conditioner, your phone must be set to automatically reconnect to your wireless network when the process is complete.

Kindly reminder:

- All the steps for network configuration must be completed within 8 minutes after powering on the air conditioner, otherwise you will need to power it off and on again.

NOTE:

- Make sure your devices are powered on.
- Keep your mobile phone close enough to the unit when you are configuring the network for the unit.
- Connect your mobile phone to the wireless network at home and make sure you know the password of the network.
- Check if your router supports the 2.4 GHz wireless band and that it is turned on. If you are not sure whether the router supports the 2.4 GHz band, please contact the router manufacturer.
- The device cannot connect to the wireless network that requires authentication. Typically the wireless network in public areas such as hotels, restaurants, etc., works in this way. Please connect to a wireless network that does not require authentication.
- It is recommended to use a wireless network name that only contains letters and numbers and not special characters.
- If your wireless network name contains special characters, please change it on your router. Your phone and other devices will then need to reconfigure their wireless connection.
- Turn off the WLAN+ (Android) or WLAN Assistant (iOS) function of your mobile phone when configuring the unit.
- In the case that your device connected to a wireless network before, but it needs to reconnect, please click “+” on the app Home page, and add your device again by the device category and model according to the instructions on the app.

Register and log in

- Open the SmartHome app. Log in directly if you have an existing SmartHome account or create a new account. Alternatively, you can also use a 3rd party login platform.

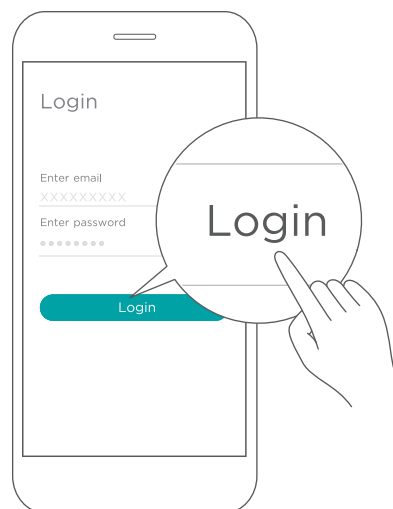

Connecting the device

1. Please make sure your mobile phone is connected to your wireless network and that Bluetooth is on.
If that is not the case, go to your phone settings and turn them on.
2. Please power on the devices you wish to connect to.
3. Open SmartHome app on your phone.
4. If the message "Smart devices discovered nearby" appears, click on this to add the automatically discovered devices.

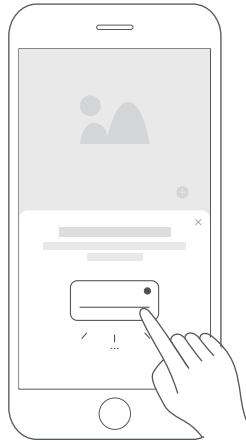

5. If no such message appears, proceed as follows:

Tap on "+" and select your device in the list of nearby available devices. If your device is not listed, please add your device manually, first selecting the device category e.g. Portable AC.

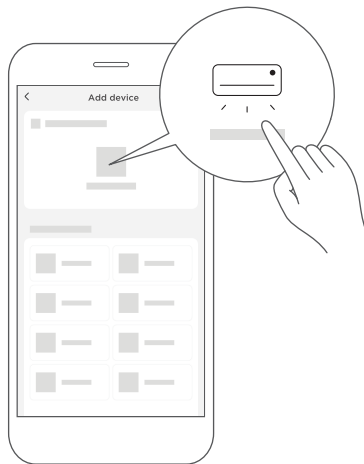

6. Follow the steps in the app to connect your device to the wireless network. If your device fails to connect, follow the additional instructions in the app.device category e.g. Portable AC.2) If no such message appears, proceed as follows:



Controlling the device

After pairing successfully, a card will be created for the device in the SmartHome app. Shortcuts for basic functions will appear on the card such as changing the temperature or switching the device on or off. Tapping on the card, will reveal additional features and settings. The actual UI design may look different from examples due to app updates.

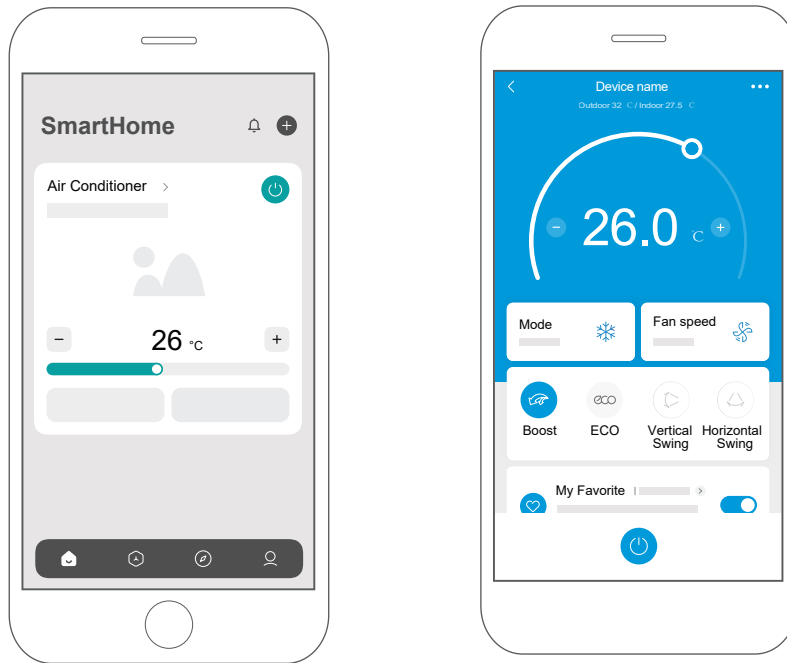

I ECO-AI Saving (Not all units)

Functional value:

- Power saving without sacrificing physical comfort when turning on the AI Saving.
- Giving the air conditioner refined control to improve stability, continuity and comfort of control.
- Giving air conditioners the goal of adapting to thermal loads + demand preferences, more closely matching user demand preferences.

Features and instructions:

Based on AI algorithms and a temperature prediction model, the compressor frequency and the internal fan speed are adjusted so as to change the room temperature, humidity and air speed to save energy and keep comfort.

Precautions:

- Must be opened via the APP.
- Need to keep the device online.
- Not available with some other functions. Please check the APP for details.

Care and Maintenance

⚠ CAUTION

UNIT DAMAGE HAZARD Failure to follow this caution may result in equipment damage or improper operation. Airflow restriction may cause damage to the unit.

FRONT PANEL AND CASE

- Always **TURN OFF** your AC system and disconnect its power supply before cleaning or maintenance.
- Only use a soft, dry cloth to wipe the unit clean. You can use a cloth soaked in warm water to wipe it clean if the unit is especially dirty.
- Do not use chemicals or chemically treated cloths to clean the unit
- Do not use benzene, paint thinner, polishing powder or other solvents to clean the unit. They can cause the plastic surface to crack or deform.
- Do not use water hotter than 40°C (104°F) to clean the front panel. This can cause the panel to deform or become discolored.

OUTDOOR COIL

- The coil on the outdoor side of the unit should be checked regularly.
- Any maintenance and cleaning of the outdoor coil should be performed by an authorized dealer or a licensed service provider.

NOTE: Never use a high-pressure spray on the coil.

AIR FILTERS

⚠ CAUTION

Failure to follow this caution may result in equipment damage or improper operation. Do not operate the unit without filters in place. If a filter becomes torn or damaged, it should be replaced immediately. Operating without filters in place or with a damaged filter will allow dirt and dust to reach the indoor coil and reduce cooling, heating, airflow, and efficiency of the unit. Airflow restriction may cause damage to the unit.

- The most important thing you can do to maintain unit efficiency is to clean the filters once every two weeks as required. Clogged filters reduce cooling, heating, and airflow

- Keeping filters clean will:

- Decrease the cost of operation.
- Save energy.
- Prevent clogged indoor coil.
- Reduce risk of premature component failure.

- To Clean Air Filters:

Vacuum off heavy soil. Run water through the filter. Dry thoroughly before replacing.

-Removing Air Filters

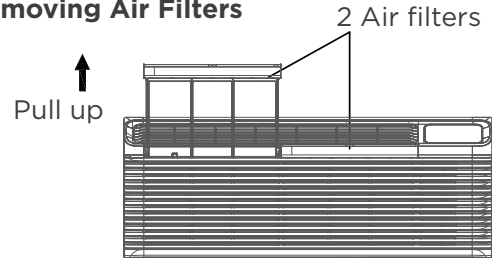

Fig. 18

-Replacing Air Filters

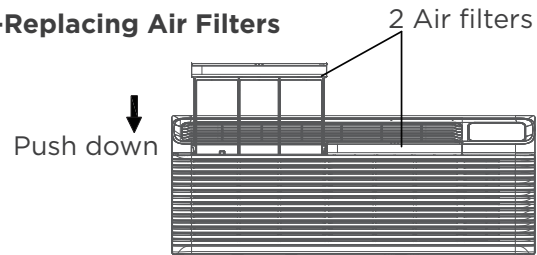

Fig. 19

VENT DOOR FILTER

Contact the authorized service technician for cleaning the vent door filter of this unit.

IMPORTANT: TURN THE UNIT OFF BEFORE CLEANING.

Clean the vent every 3 months or as required.

- Make sure to remove the shipping screw from the vent door. (See Fig. 4.)
- Press down and remove the vent door filter as shown below.
- Clean the filter. Dry thoroughly before replacing.
- Reinstall the vent door filter.

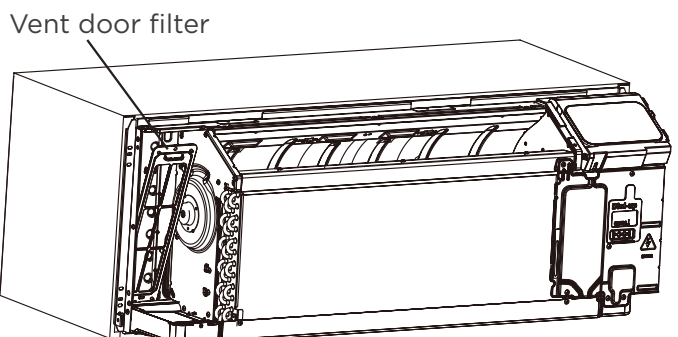

Fig. 20

Troubleshooting

Before calling for service, review this list. It may save you time and money. This list includes common occurrences that are not the result of defective workmanship or materials in this appliance.

Problem	Solution
UNIT DOES NOT START	The unit may have become unplugged. Check that the plug is plugged securely into the wall receptacle. NOTE: Plug has a test/reset button on it. Make sure that the plug has not tripped.
	Fuse may have blown. Replace the fuse. See Note 1.
	The unit may be off. Reset the circuit breaker. See Note 1.
UNIT NOT COOLING/ HEATING ROOM	The unit air discharge section is blocked. Make sure that curtains, blinds or furniture are not restricting or blocking unit airflow.
	The temperature setting is not high or low enough. NOTE: Set-point limits may not allow the unit to heat or cool the room to the desired temperature. Check the section on DIP switch settings. Reset to a lower or higher temperature setting.
	Unit air filters are dirty. Remove and clean filters.
	The room is excessively hot or cold when the unit is started. Allow enough time for the unit to heat or cool the room. Start heating or cooling early before outdoor temperature, cooking heat, or gatherings of people make the room uncomfortable.
	Vent door left open. Close the vent door.
	The unit may be in protection mode. Check the DIP switch and wall thermostat settings for desired comfort.
DISPLAY HAS STRANGE NUMBERS/ CHARACTERS ON IT	The unit may be in a protection mode.
UNIT MAKING NOISES	Clicking, gurgling, and whooshing noises are normal during the operation of the unit.
WATER DRIPPING OUTSIDE	If a drain kit has not been installed, condensation runoff during very hot and humid weather is normal. See Note 2. If a drain kit has been installed and is connected to a drain system, check gaskets and fittings around drain for leaks and plugs.
WATER DRIPPING INSIDE	The wall sleeve is not installed level. The wall sleeve must be installed level for proper drainage of condensation. Check that the installation is level and make any necessary adjustments.

Problem	Solution
ICE OR FROST FORMS ON INDOOR COIL	Low outdoor temperature. When the outdoor temperature is approximately 55°F or below, frost may form on the indoor coil when the unit is in Cooling mode. Switch the unit to FAN operation until ice or frost melts.
	The filters are dirty. Remove and clean filters.
COMPRESSOR PROTECTION	Power may have cycled, so the compressor is in a restart protection. Random Compressor restart - Whenever the unit is plugged in or power has been restarted, a random compressor restart will occur. After a power outage, the compressor will restart after approximately 3 minutes. Compressor Protection - To prevent short cycling of the compressor, there is a random startup delay of 3 minutes and a minimum compressor run time of 3 minutes.
ELECTRIC HEATING FAILURE	Clean the evaporator once every three months by a professional.

NOTES:

1. If the circuit breaker is tripped or the fuse is blown more than once, contact a qualified electrician.
2. If the unit is installed where condensation drainage could drip in an undesirable location, an accessory drain kit should be installed and connected to the drain system.