

Spec Sheet

Genuine Comfort Through-The-Wall Air Conditioner

Fits TTW Sleeves Between 25-1/2" to 27" Wide

FEATURES

- Digital controls
- Dehumidify Mode
- Energy Saver & Sleep Mode
- 24-Hour Programmable Timer
- Adjustable Air Louvres
- Three Indoor Fan Speeds
- Slide-Out Washable & Easy-Clean Filter
- Hand Held Remote Control (Included)
- Error Code Display For Easy Diagnostic
- Universal Thru-The-Wall Install Kit
- Genuine Care Warranty: 1-Year Unit Replacement



MODEL IDENTIFICATION

Example: **GCTTW-C10KA0-2**

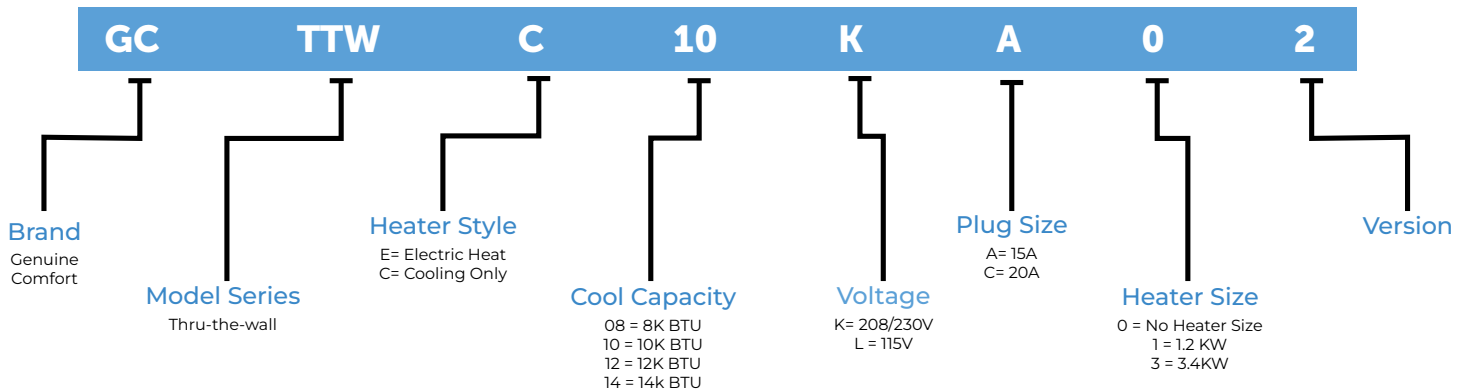

PLUG TYPE

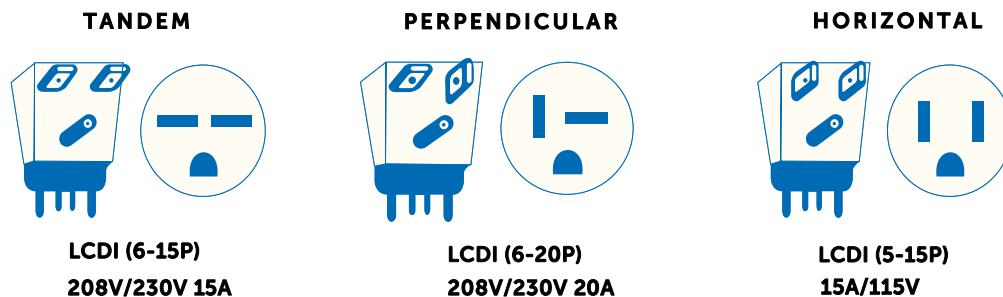

SPECIFICATIONS (COOLING W/ ELECTRIC HEAT)

Model ID		GCTTWE08LA1-2	GCTTWE10KC3-2	GCTTWE12KC3-2
Power Supply	Voltage (1 Ph., 60Hz)	V	115	208/230
	Capacity	Btu/h	8,000	9,800/10,000
Cooling	Input	W	750	980/1000
		EER	10.7	10
	Capacity	(BTU/H)	4,200	8,600/10,600
Electric Heater	Power Input	W	1,220	2,821/3,450
	Amps	A	11	14/15
Max Input Consumption	W	1,350	3,450	3,450
Max Current	A	11	15	15
Indoor Air Flow (L/M/H)	CFM	192 / 227 / 258	241 / 263 / 285	230 / 251 / 273
Indoor Sound Level (L/M/H)	dB(a)	52 / 55.4 / 58.7	58 / 60.3 / 62.2	58 / 60 / 61.8
Outdoor Noise Level	dB (a)	63.5	66.3	65.4
Ambient Temp (Out-door)	Cooling	C°	18 - 43	18 - 43
	Cooling	F°	64 - 109	64 - 109
Unit Dimensions (W x D x H)	inch	24.21 * 20.28 * 14.53	24.21 * 20.28 * 14.53	24.21 * 20.28 * 14.53
Package Dimensions (W x D x H)	inch	27.95 * 26.57 * 16.93	27.95 * 26.57 * 16.93	27.95 * 26.57 * 16.93
Net Weight / Gross Weight	lbs	67 / 77	68 / 78	75 / 86
Refrigerant Type		R32	R32	R32
Cord Type		LCDI(5-15P)	LCDI(6-20P)	LCDI(6-20P)
Cord Length	Ft	5.6	5.6	5.6

SPECIFICATIONS (COOLING ONLY)

Model		GCTTWC10LA0-2	GCTTWC12LA0-2
Power Supply	Voltage (1 Ph., 60Hz)	V	115
	Capacity	Btu/h	10,000
Cooling	Input	W	930
		EER	10.6
Max Input Consumption	W	1,290	1,420
Max Current	A	12.9	14
Indoor Air Flow (L/M/H)	CFM	191 / 220 / 256	220 / 250 / 276
Indoor Sound Level (L/M/H)	dB(a)	50.2 / 52.8 / 55.8	55.3 / 56.8 / 59
Outdoor Noise Level	dB (a)	64.3	68.7
Ambient Temp (Outdoor)	Cooling	C°	18 - 43
	Cooling	F°	64 - 109
Unit Dimensions (W x D x H)	inch	24.21 * 20.28 * 14.53	24.21 * 20.28 * 14.53
Package Dimensions (W x D x H)	inch	27.95 * 26.57 * 16.93	27.95 * 26.57 * 16.93
Net Weight / Gross Weight	lbs	67 / 79	75 / 88
Refrigerant Type		R32	R32
Cord Type		LCDI(5-15P)	LCDI(5-15P)
Cord Length	Ft	7.02	7.02

SPECIFICATIONS (COOLING ONLY) (CONTINUED)

Model			GCTTWC10KA0-2	GCTTWC12KA0-2	GCTTWC14KA0-2
Power Supply	Voltage (1 Ph., 60Hz)	V	208/230	208 / 230	208 / 230
	Capacity	Btu/h	10,200/10,500	11,700/ 12,000	13,600 / 1,400
Cooling	Input	W	940/970	1,110 / 1,140	1,360 / 1,400
		EER	10.6	10.5	9.5
Max Input Consumption		W	1,235	1,472	1,818
Max Current		A	6.7	7.9	9.7
Indoor Air Flow (L/M/H)		CFM	248 / 272 / 291	273 / 259 / 274	254 / 264 / 280
Indoor Sound Level (L/M/H)		dB(a)	55.7 / 57.9 / 59.4	57.5 / 59 / 60.2	58 / 59.5 / 60.5
Outdoor Noise Level		dB (a)	68.5	68.3	69.9
Ambient Temp (Outdoor)	Cooling	C°	18 - 43	18 - 43	18 - 43
	Cooling	F°	64 - 109	64 - 109	64 - 109
Unit Dimensions (W x D x H)		inch	24.21 * 20.28 * 14.53	24.21 * 20.28 * 14.53	24.21 * 20.28 * 14.53
Package Dimensions (W x D x H)		inch	27.95 * 26.57 * 16.93	27.95 * 26.57 * 16.93	27.95 * 26.57 * 16.93
Net Weight / Gross Weight		lbs	68 / 80	74 / 87	75 / 88
Refrigerant Type			R32	R32	R32
Cord Type			LCDI(6-15P)	LCDI(6-15P)	LCDI(6-15P)
Cord Length		Ft	6.5	6.5	6.5