

Spec Sheet

Genuine Comfort Casement/Vertical Window AC

Unit Size: 14.57"W x 23.5"D x 20.87"H

FEATURES

- Digital Controls
- Easy mount window installation kit included
- Hand Held Remote Control (Included)
- Dehumidify Mode
- Three Indoor Fan Speeds
- Clean Air Feature (Ion Generator)
- Energy Saver mode
- 24-Hour Programmable Timer
- Exhaust Control (Outside Fresh Air)
- Sleep mode
- Adjustable Air Louvers
- Slide-Out Washable & Easy-Clean Filter
- Filter Replacement Reminder
- Error Code Display for easy Diagnostic
- Follow Me (Remote Control acts as Thermostat)
- R32 Refrigerant
- Genuine Care Warranty: 1 Year Unit Replacement



ACCESSORIES

* SOLD SEPARATELY

Window Sleeve

Our AC window sleeves are sturdy, precisely engineered casings designed to securely house and support your AC unit through a window. Crafted with high-quality materials and built for easy installation, these sleeves offer durable protection and a seamless fit, ensuring optimal performance for your HVAC system.



MODEL IDENTIFICATION

Example: GCCSE-C10LA0-2

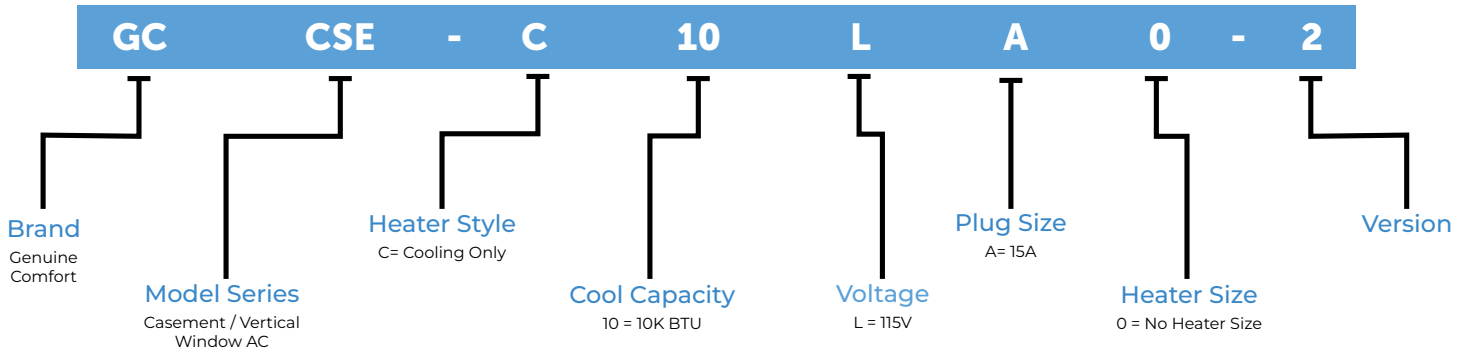

PLUG TYPE

HORIZONTAL

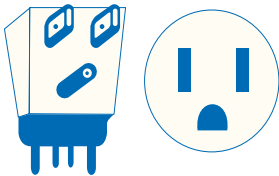

115V 15A

SPECIFICATIONS (COOLING)

Model ID		GCCSE-C10LA0-2	
Power Supply	Voltage (1 Phase, 60Hz)	V	115
	Capacity	Btu/h	10,000
Cooling	Input	W	961
		EER	10.4
Max Input Consumption		W	1,040
Max Current		A	10.45
Indoor Air Flow (L/M/H)		CFM	264 / 294 / 323
Indoor Sound Level (L/M/H)		dB(a)	55 / 57 / 59
Outdoor Sound Level		dB (a)	67.5
Ambient Temp (Indoor)	Cooling	C°	17 - 32
	Cooling	F°	62 - 89
Ambient Temp (Outdoor)	Cooling	C°	18 - 43
	Cooling	F°	64 - 109
Unit Dimensions (W x D x H)		inch	14.57 x 23.5 x 20.87
Package Dimensions (W x D x H)		inch	18.31 x 26.57 x 23.03
Net Weight / Gross Weight		lbs	74 / 87
Refrigerant Type			R32
Cord Type			LCDI(5-15P)
Cord Length		Ft	7.48